

StarLine E9 V3 LoRa

Vehicle security and telematic system connection diagram

! For the cars equipped with CAN/LIN bus make a connection via the embedded digital CAN/LIN interface, for the elder cars make an analogue connection.
Find information and wiring tips on vehicles and features supported with CAN/LIN connection at can.starline.bz

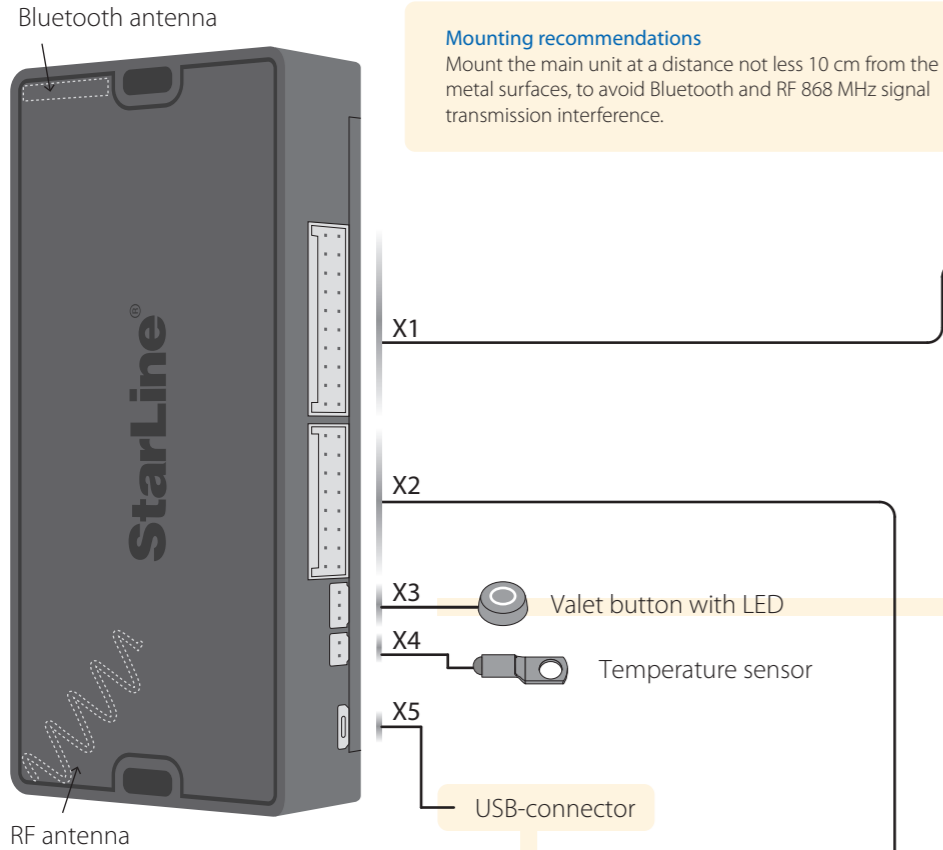

Mounting recommendations
Mount the main unit at a distance not less 10 cm from the metal surfaces, to avoid Bluetooth and RF 868 MHz signal transmission interference.

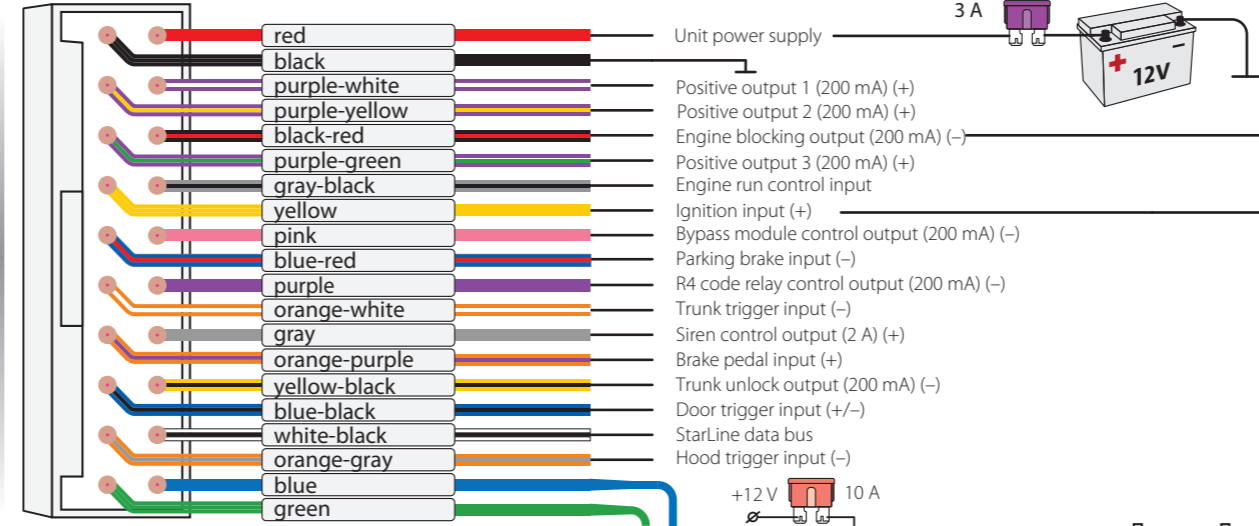

X3 channel automatically detects the type of connected device (external transceiver or service button). Auto detection is active when the channel function is "Not set" in configuration.

! Check other available connection options at help.starline.ru

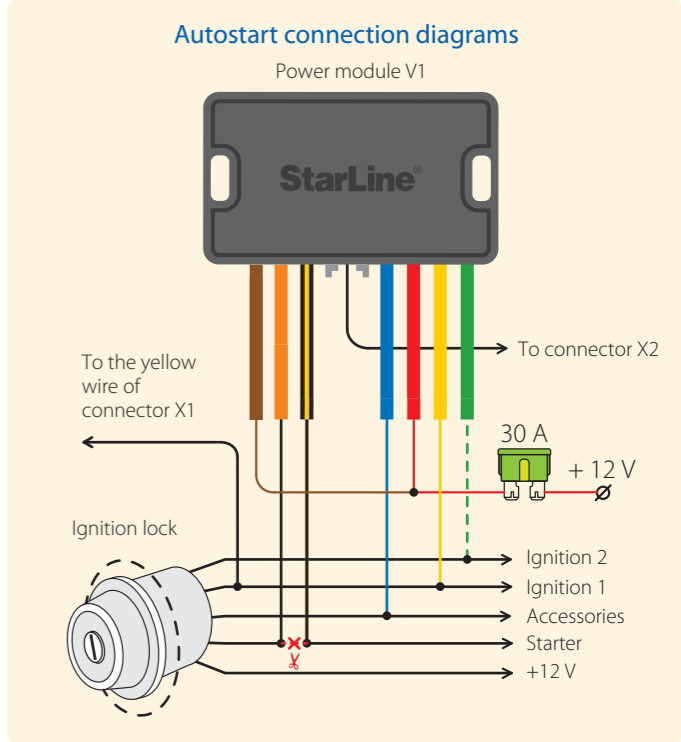
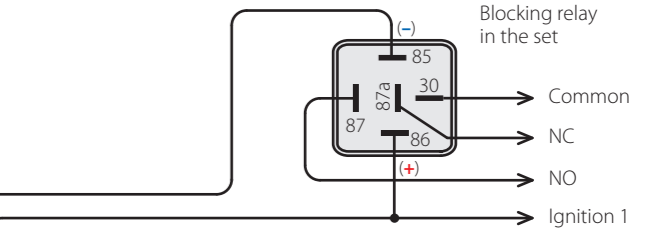
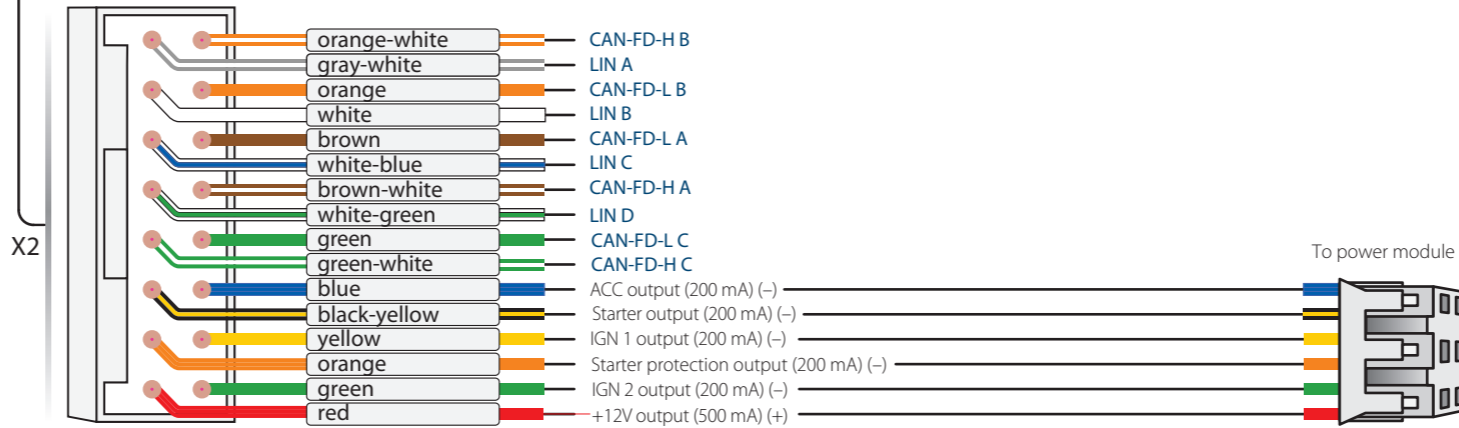

Set X2:6 blue wire as Starter protection and X2:15 orange wire as Engine start: ACC in StarLine Master configuration program.

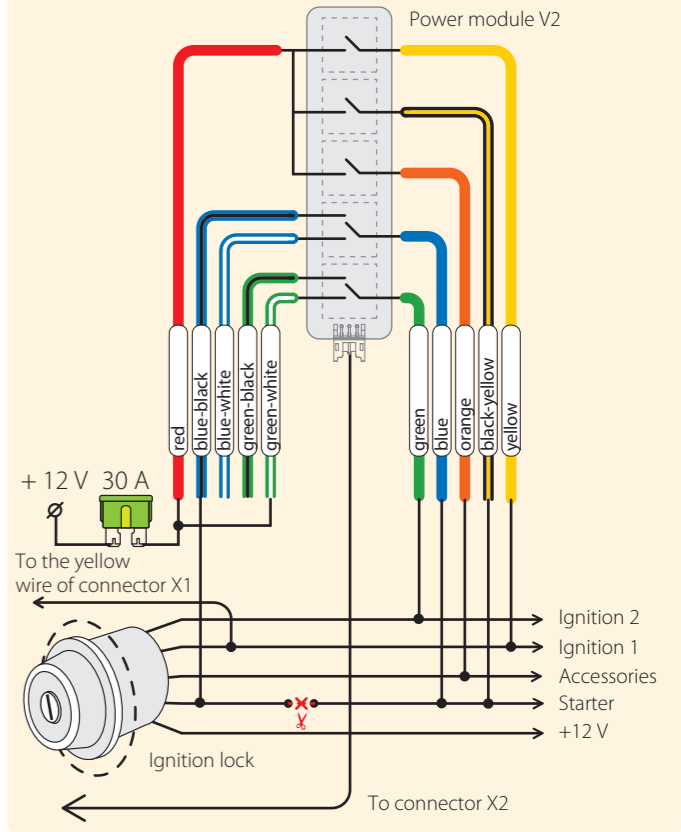

For convenient setup, diagnostics and software upgrade use the free StarLine Master software available at help.starline.ru

! The manufacturer StarLine ScPA LLC reserves the right to make technical improvements not shown in this diagram.
Information on firmware updates, actual versions of operation and installation manuals are available at help.starline.ru.

General installation specifications

- The security system is designed for installation on vehicles with 12V on board voltage.
- Prior to installation, make sure that the vehicle equipment circuits, to which the system is connected, are in suitable operating condition and no any trouble codes and check engine are indicated.
- The system installation should be carried out according to the connection diagram.
- The "ground" wire of the main unit should be connected first to a car body ground with an original screw.
- Mount the wiring far from sources of electrical interference: ignition coils, high-voltage wires, etc.
- Make sure that the harness is not lay in contact with the moving parts of the vehicle: pedals, steering shaft etc.
- Connect all the harness to the main unit sockets only after all wires mounting is complete.
- Do not fit the engine temperature sensor near the exhaust manifold, otherwise it may cause sensor overheating and damage.
- Only the qualified and trained fitter may carry out the security system installation.
- The configured parameters of the security systems must comply with a vehicle manual instruction requirements.

StarLine E9 v3 LoRa

Additional connection options Configuring the security and telematic system

Diagram of start circuits connection on vehicles with PTS button

- In StarLine Master program set X2:6 blue wire as "Engine start: simulate brake or clutch pedal" and X2:14 black-yellow wire as "Engine start: PTS button".
- Connect wires according to diagram for corresponding power module.

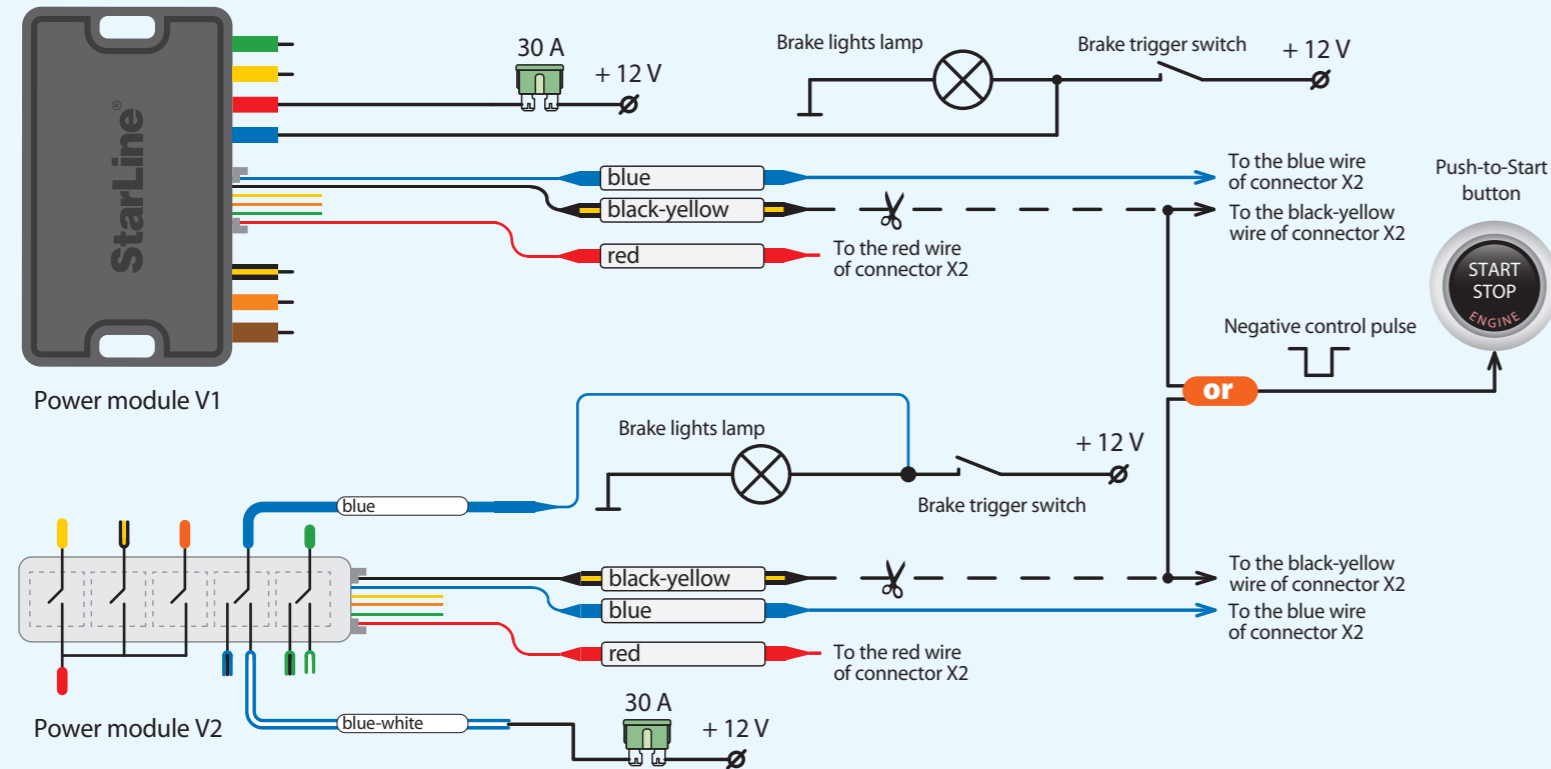

NOTE! The tags included in the delivery set are already registered in the main unit and are in the transport mode, i.e. off. Pressing the tag button in this mode will be indicated by a green and red flashes of the built-in LED. Prior to operation press the tag button several times until the LED color turn to green (regular mode).

New devices registration

NOTE! At registration of new tags and smartphones all previously registered tags and smartphones will be erased from memory. So the existing devices should be registered simultaneously in one cycle with all the new devices. In total up to 5 Bluetooth devices can be registered in the system main unit. When new RF pagers are registered, all previously registered remote keys will be erased from memory. So the existing remote keys should be registered simultaneously in one cycle with all the new remote keys. In total, up to 4 RF pagers can be registered in the system main unit.

Switch to device registration mode

- Disarm the security system.
- Switch ignition Off if it is On.
- Press the service button 7 times.
- Switch ignition On. 7 light LED flashes of service button and 7 buzzer sounds will follow.
- 2 short LED flashes and buzzer sounds will confirm entry into the Registration mode.

2-way remote control (pager) registration

- Press a pager buttons 1 and 2 shortly.
- In 3 seconds successful registration will be confirmed by a short beep sound of a pager, 2 LED flashes of service button and 2 buzzer sound signals. If pager is not registered, 4 beep sounds of pager will follow.
- Repeat points 6-7 for each pager.

Bluetooth tags (transponders) registration

- Remove a battery from tag.
- Hold a tag button pressed and insert a battery back. A tag LED will turn red.
- Release a button, a series of red flashes will follow.
- In 10 seconds successful registration will be confirmed by a green LED flash, 2 flashes of a service button LED and 2 buzzer sounds. If a tag is not registered LED will turn red.
- Repeat points 9-12 for all the remaining tags.

Smartphone registration

- Register a smartphone* with use of the free StarLine mobile App.

Exit from the device registration mode

- In 10 seconds switch ignition Off to exit the registration mode. An exit from Registration mode will be confirmed by double LED flashes and buzzer sounds and then additional signals in amount of total registered tags, pagers and smartphones will follow.

* The iOS and Android smartphone with Bluetooth Smart 4.2 and above are supported.

Eberspächer heater connection with data bus control

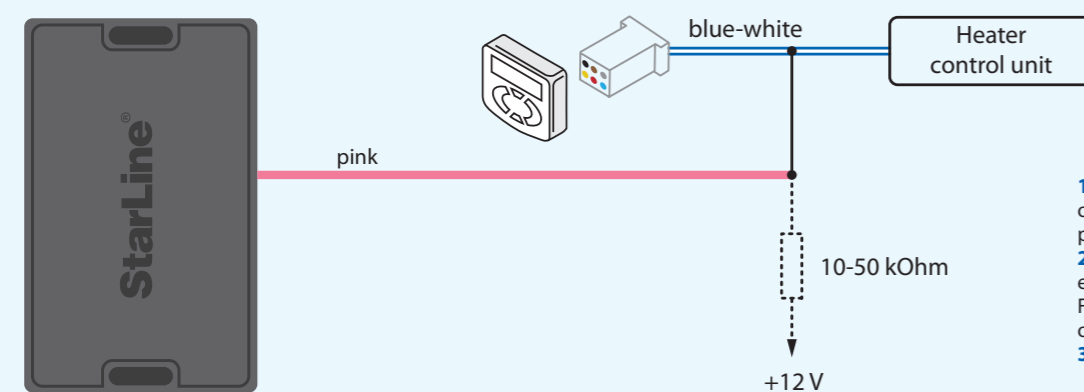

- In StarLine Master program set the pink output wire of X1 connector as "Eberspächer preheater control via digital bus".
- In "Engine start" section "Starting preheater" enable "Permission for preheater operation". For the point "Start type of preheater" select option "Eberspächer via digital bus".
- Connect the wires according to the diagram.

Webasto heater connection with data bus control

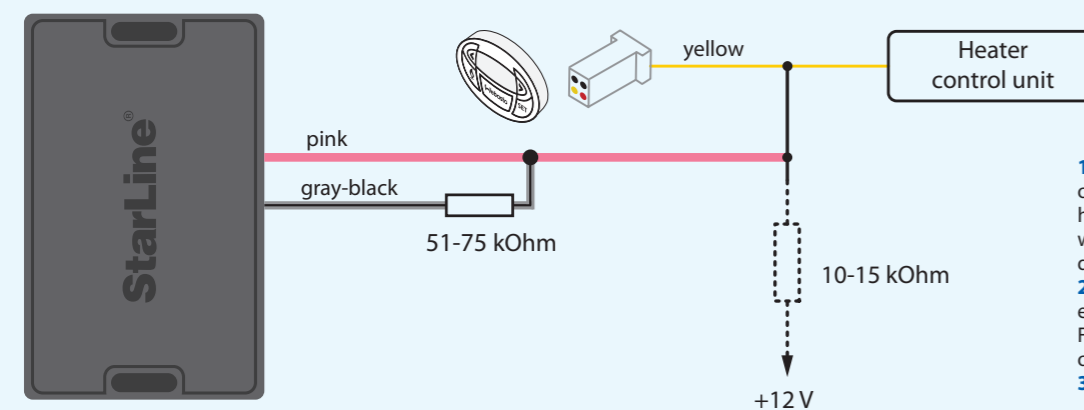

- In StarLine Master software set the pink output wire of X1 connector as "Webasto heater control via digital bus", the gray-black wire – as "Webasto preheater start control via digital bus".
- In "Engine start" section "Starting preheater" enable "Permission for preheater operation". For the point "Start type of preheater" select option "Webasto via digital bus".
- Connect the wires according to the diagram.

Programming an owner authorisation code (with car buttons)

- Disarm security system.
- Switch ignition Off, if it is On, then press service button 7 times.
- Switch ignition On.
- 7 LED flashes of service button and 7 buzzer sounds will follow.
- Then 2 LED flashes of service button and 2 buzzer sound signals will follow, confirming entry into Registration mode.
- Enter the owner authorization code using car OEM buttons with a pressing interval no more than 3 seconds. Every button pressing should be followed by a single service button LED flash. The owner authorization code consists of a code sequence containing from 3 to 30 OEM buttons pressing. The list of supported OEM buttons is available at can.starline.bz. If a service button LED flash does not follow after pressing of OEM button, so this button is not supported for this car.
- In 3 seconds after the code entry 2 short LED flashes and 2 buzzer sound will follow, confirming the code successful registration.
- Enter the owner authorization code again.
- If the code is recorded properly, 2 LED flashes and 2 short buzzer sound will confirm. If the code recording is failed, so 4 short buzzer sounds will follow, in this case repeat steps 6-8.
- In 10 sec switch ignition Off to exit the Registration mode.
- An exit from Registration mode will be confirmed by double LED flashes and buzzer sounds and then additional signals in amount of total registered tags, pagers and smartphones will follow.
- Write down and memorize this push sequence.